

⚠ WARNING

To avoid unpredictable system behavior that can cause personal injury and property damage:

- Disconnect electrical supply (when necessary) before installation, servicing, or conversion.
- Disconnect air supply and depressurize all air lines connected to this product before installation, servicing, or conversion.
- Operate within the manufacturer's specified pressure, temperature, and other conditions listed in these instructions.
- Medium must be moisture-free if ambient temperature is below freezing.
- Service according to procedures listed in these instructions.
- Installation, service, and conversion of these products must be performed by knowledgeable personnel who understand how pneumatic products are to be applied.
- After installation, servicing, or conversion, air and electrical supplies (when necessary) should be connected and the product tested for proper function and leakage. If audible leakage is present, or the product does not operate properly, do not put into use.
- Warnings and specifications on the product should not be covered by paint, etc. If masking is not possible, contact your local representative for replacement labels.

Introduction

Follow these instructions when installing, operating, or servicing the product.

Application Limits

These products are intended for use in general purpose compressed air systems only. Compliance with the rated pressure and temperature is necessary.

Maximum Operating (Inlet) Pressure:	kPa	PSIG	bar
Mini Regulator (Plastic Body)	827	120	8.32
Economy Regulator (Metal Body)	1720	250	17.2

Ambient Temperature Range: 0°C to 52°C (32°F to 125°F)

⚠ WARNING

Product rupture can cause serious injury.
Do not connect regulator to bottled gas.
Do not exceed maximum primary pressure rating.

Symbol



Miniature & Economy Regulators
(Relieving)

Installation

1. This unit should be installed with reasonable accessibility for service whenever possible - repair service kits are available. Keep pipe and tubing lengths to a minimum with inside clean and free of dirt and chips. Pipe joint compounds should be used sparingly and applied only to the male pipe - never into the female port. Do not use PTFE tape to seal pipe joints - pieces have a tendency to break off and lodge inside the unit, possibly causing malfunction.
2. Install unit so that air flow is in the direction of arrow. Installation must be upstream of and close to devices it is to service (valve, cylinder, tool etc.) Mounting of Regulators may be in any position.
3. Gauge ports are located on both sides of the regulator body for your convenience. It is necessary to install a gauge or pipe plug into each port during installation.
4. To protect Regulator units against rust, pipe scale, and other foreign matter, install a filter on the upstream (high pressure) side as close to the regulator as possible.

⚠ Caution: For proper assembly of units having plastic bodies, fittings must be installed hand-tight and then tightened by wrench 1/2 turn. To prevent leakage past threads, apply thread sealant to fitting. Prestolok fittings are recommended. Use of hard pipe is not recommended.

EXCESSIVE TURNING OF FITTINGS BY WRENCH MAY RESULT IN PERMANENT DAMAGE AND RENDER THE REGULATOR INOPERABLE.

Operation of Regulator

1. Before turning on air supply, turn adjusting handle counterclockwise until compression is released from control spring. Then turn on air supply and adjust regulator to desired secondary pressure by turning adjusting handle clockwise. This permits pressure to build up slowly, preventing any unexpected operation of the valve, cylinders, tools, etc., attached to the line. Adjustment to desired secondary pressure can be made only with primary pressure applied to the regulator.
2. To decrease regulator pressure setting, always reset from a pressure lower than the final setting desired. For example, lowering the secondary pressure from 550 to 410 kPa (80 to 60 PSIG) is best accomplished by dropping the secondary pressure to 350 kPa (50 PSIG), then adjusting upward to 410 kPa (60 PSIG).

Service

⚠ Caution: SHUT OFF AIR SUPPLY and exhaust the primary and secondary pressure before disassembling unit. (Units may be serviced without removing them from the air line.)

Servicing Regulator:

Note: See Figure 1, 2 & 3 to aid with this procedure.

1. Unlock the adjusting knob by pulling upward (with the unit in an upright position.) Then turn adjusting knob counterclockwise until compression of the control spring has been removed.
2. Remove the bonnet from body. Then remove o-ring (3), piston, lip seal (5), and control spring (8) to service the bonnet subassembly. Unscrew seat (4) to service the poppet (13), return spring (1), and / or poppet seal (2), o-rings (16 & 18), and washer (17).
3. Clean old grease from unit and inspect seals for sign of wear (nicks, cuts, and scratches). Repair kits are available which contain the parts which are typically replaced.
4. Apply a light film of grease to all seals and sliding surfaces using the grease packet supplied with repair kit.

Note: Refer to Figures to determine the correct position and orientation of the various parts during assembly.

⚠ WARNING

FAILURE OR IMPROPER SELECTION OR IMPROPER USE OF THE PRODUCTS AND/OR SYSTEMS DESCRIBED HEREIN OR RELATED ITEMS CAN CAUSE DEATH, PERSONAL INJURY AND PROPERTY DAMAGE.

This document and other information from The Company, its subsidiaries and authorized distributors provide product and/or system options for further investigation by users having technical expertise. It is important that you analyze all aspects of your application, including consequences of any failure and review the information concerning the product or systems in the current product catalog. Due to the variety of operating conditions and applications for these products or systems, the user, through its own analysis and testing, is solely responsible for making the final selection of the products and systems and assuring that all performance, safety and warning requirements of the application are met.

The products described herein, including without limitation, product features, specifications, designs, availability and pricing, are subject to change by The Company and its subsidiaries at any time without notice.

EXTRA COPIES OF THESE INSTRUCTIONS ARE AVAILABLE FOR INCLUSION IN EQUIPMENT / MAINTENANCE MANUALS THAT UTILIZE THESE PRODUCTS. CONTACT YOUR LOCAL REPRESENTATIVE.

5. On Relieving Economy Regulator units, gently and firmly press vent seal into piston using a blunt instrument.
6. Install lip seal onto piston with the lips of the seal facing away from the support flange. Then insert control spring and piston assembly into bonnet.
7. On Economy Regulator units, place balancing o-ring (18) and washer (17) into body's bore. Then insert poppet return spring and poppet assembly, followed by seat o-ring (16) and seat. On Mini-Regulator units, place poppet return spring and poppet assembly into bore, followed by poppet seal and seat.
8. On Economy Regulator units, tighten seat from 0.6 to 0.8 Nm (5 to 7 in-lbs). On Mini Regulator units, tighten seat to body from 0.9 to 1.1 Nm (8 to 10 in-lbs). Tighten bonnet onto body from 5.6 to 7.3 Nm (50 to 65 in-lbs) of torque.
9. Make sure that the control spring is still uncompressed before turning on the air supply. Turn on air supply, then slowly adjust the knob clockwise to increase downstream pressure until the desired pressure has been reached.
10. To decrease regulator pressure setting, always reset from a pressure lower than the final setting desired. For example, lowering the secondary pressure from 550 to 410 kPa (80 to 60 PSIG) is best accomplished by dropping the secondary pressure to 350 kPa (50 PSIG), then adjusting upward to 410 kPa (60 PSIG).
11. When the desired secondary pressure setting has been reached, push the adjusting knob down to lock it.
12. Check for leaks. If leaks occur, shut off the air supply, exhaust system air pressure, and make necessary adjustments to eliminate leakage.

Service Kits Available

The following service kits contain the appropriate seals and parts necessary for ordinary field service.

Description	Mini Regulator	Economy Regulator
Bonnet Assembly	L01369	L01369
Mounting Bracket Kit (plastic ring)	PS417B	PS417B
Mounting Bracket Kit (aluminum ring)	PS466	PS466
Panel Mount Nuts		
Plastic	P78652	P78652
Metal	P01531	P01531
Piston Kit - Non-Relieving	N/A	PS422
Piston Kit - Relieving	N/A	PS423
Piston & Poppet Kit - Unbal. Rel.	PS426	N/A
Piston & Poppet Kit - Bal. Rel.	PS427	N/A
Piston & Poppet Kit - Unbal. Non-Rel.	PS428	N/A
Piston & Poppet Kit - Bal. Non-Rel.	PS429	N/A
Poppet Kit - Balanced	N/A	PS455B
Poppet Kit - Unbalanced	N/A	PS454
Tamperproof Kit	P01265	P01265

Parts Identification List

Item#	Description
1	Poppet Return Spring
2	Poppet Seal
3	O-ring - body to bonnet
4	Seat
5	Lip Seal - piston to bonnet
6	O-ring - piston to poppet (Mini Regulator)
7	Piston (relieving shown)
8	Control Spring
9	Knob
10	Hex Nut
11	Adjusting Screw
12	Bonnet Assembly
13	Poppet (Mini Regulator) and Poppet Assembly (Economy Regulator)
14	Body
15	Vent Seal - poppet assembly to piston (relieving units) (Economy Regulator)
16	O-ring - seat to body (Economy Regulator)
17	Washer (balanced units)
18	O-ring (balanced units) - poppet assembly to body

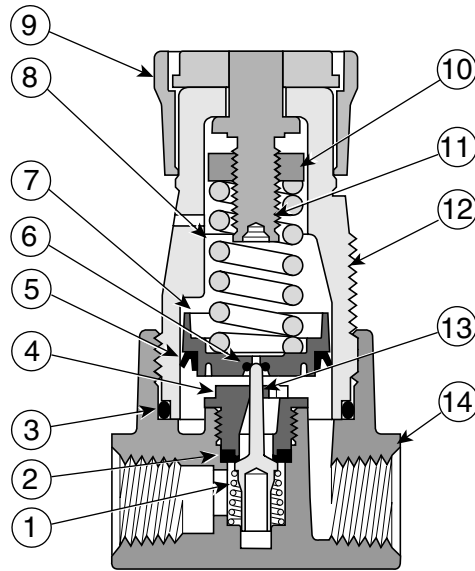

FIGURE 1: Mini Regulator - (Unbalanced, Relieving Unit Shown)

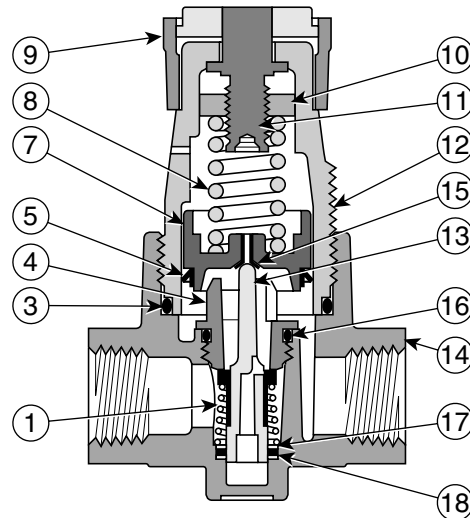

FIGURE 2: Economy Regulator - (Balanced, Relieving Unit Shown)

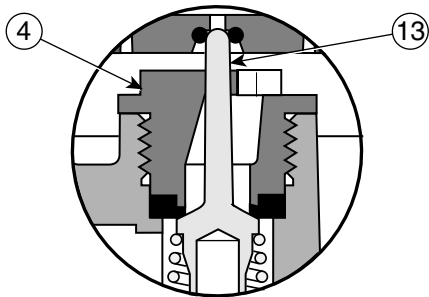

FIGURE 3: Detail of Poppet Seal - for Mini Regulators